

International Building Codes (IBC) 2000, 2003 and 2006 for Generator Systems in Areas of Seismic Activity

Information Sheet # 29

Several areas of the U.S. are designated as areas of higher seismic activity. (See diagram 2) For such areas, system designers must consider the International Building Code standards for key buildings applicable to those areas.

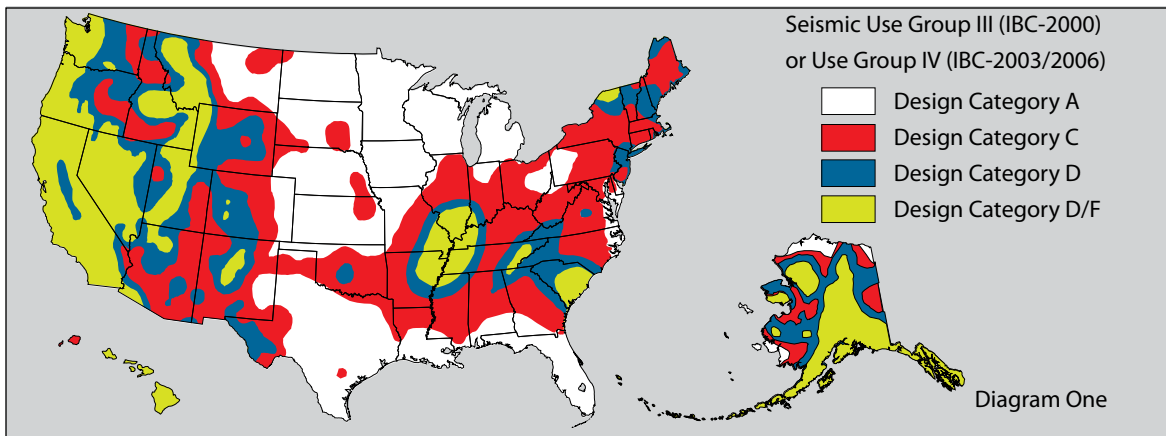

Code Development: Prior to the latest IBC publication, building codes for seismic prone areas focused on a structure's ability to withstand seismic loads and the anchorage of internal equipment. New IBC codes now consider critical equipment to be part of a structure and require certification of an equipment's ability to perform after experiencing seismic shocks.

Applicable Code: International Building Code (IBC) 2000, 2003 & 2006 is an ICC publication funded by FEMA.

International Code Council (ICC): ICC was formed to draft one set of national construction codes and encompasses:

- 1) Building Officials and Code Administrators (BOCA)
- 2) International Conference of Building Officials (ICBO)
- 3) Southern Building Code Congress International (SBCCI)

Definition of seismic: Seismic is the term given to forces resulting from the motions of an earthquake. Seismic forces affecting structures primarily move horizontally, but there may be significant vertical ones too.

Enforcement of IBC: The IBC code is not a government mandate. However, all states are expected to adopt the codes and FEMA will withhold emergency funding for states that fail to comply. All 50 states and Washington D.C. had adopted the code at state or local levels as of 4/10/2008.

Specifics of the IBC code: If a building is still standing after the seismic shocks triggered by an earthquake, systems or components within that building labeled EMERGENCY, such as an emergency generator system, must continue to function. The IBC specifies detailed responsibilities that equipment manufacturers, suppliers, installers, design team managers and engineers are required to follow to design and install a life safety component that must remain **On-line and Functional** after a seismic emergency (Refer to seismic use groups III (IBC-2000) and IV (IBC-2003/2006) building for buildings and other structures designated as essential facilities such as hospitals, fire/rescue/police stations, shelters, etc)

Certification - Manufacturers providing equipment termed "EMERGENCY" ($I_p = 1.5$), must have their equipment certified by testing, independent analysis or a combination of both to verify essential functions will perform after a seismic event.

Emergency generation systems for certification - Generators, sub-base tanks, day tanks, pumps, piping, mufflers, exhaust system, radiators, enclosures and electrical components are tested for IBC certification. (See diagrams 1, 3, 4 & 5)

Buildings and Structures Designated as Essential Facilities: The following chart details sample building and structures seismic use group III (IBC-2000) and use group IV (IBC-2003/2006) building codes, designate as essential facilities:

Hospital and other healthcare facilities with surgery and emergency treatment	Power stations and other public utility facilities required for category III/IV structures
Fire, rescue and police stations and emergency vehicle garages	Structures containing max. allowable highly toxic materials per section 307 table 307.7 (2)
Designated earthquake, hurricane or other emergency shelters	Buildings and other structures having critical national defense functions
911, communication, data, switching, operation centers	Water treatment facilities required to maintain water pressure for fire suppression

To fulfill our commitment to be the leading supplier and preferred service provider in the Power Generation Industry, the Clifford Power Systems, Inc. team maintains up-to-date technology and information standards on Power Industry changes, regulations and trends. As a service, our **Information Sheets** are circulated on a regular basis, to existing and potential Power Customers to maintain awareness of changes and developments in engineering standards, electrical codes, and technology impacting the Power Generation Industry.

Diagram one - Seismic arrangement for vibration isolators

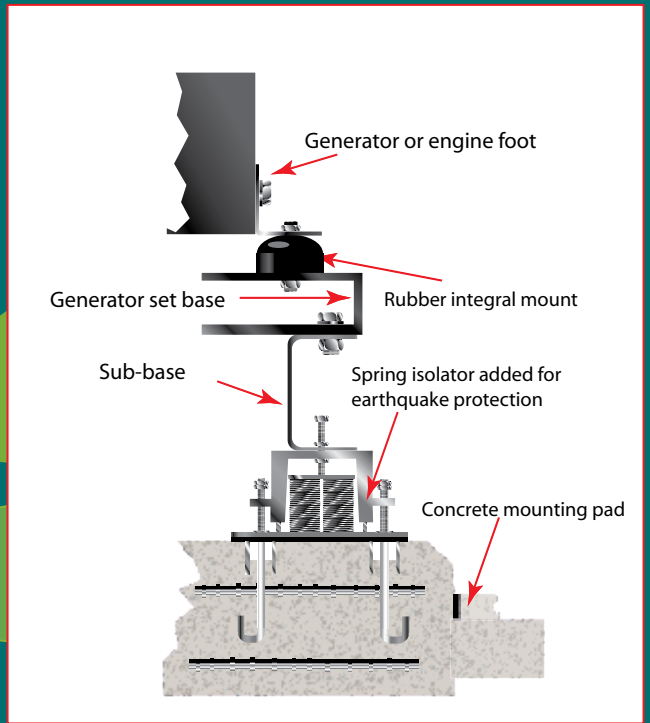
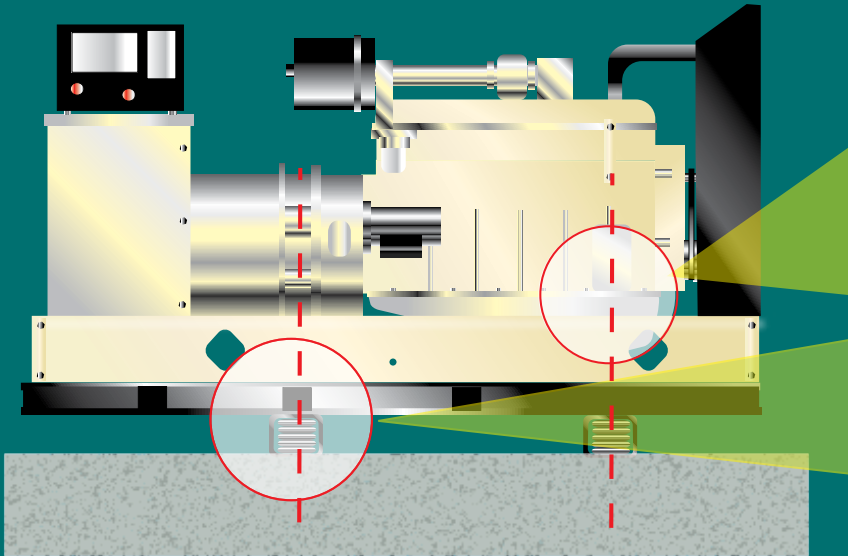

Some state and local codes require vibration isolators that provide protection for seismic or earthquake ground effects. If the generator set is already fitted with integral neoprene mounts, the addition of spring mounts for earthquake conditions should be as detailed. The spring mounts should equal the integral mounts and be located in the skid rails vertically in line with the existing neoprene isolators.

When is Seismic Certification Required? - The following three parameters dictate when certification is required:

- 1) An S_{DS} of 0.167 or greater
- 2) Building classification or seismic use group III, (IBC200) of IV, (IBC-2003/2006) (See sample chart above)
- 3) Seismic design category of C, D, E, or F (See diagram 2)

Defining the seismic level required - To determine the specific seismic level for any given installation, the specifying engineer must provide the seismic local code requirement, installation zip code, facility occupancy, the short and normal mapped spectral accelerations, site soil class, below or above grade, and, if installed inside, height of building and height location of equipment. (See diagram 2)

Requirements to attain guideline detailed in IBC - The generator manufacturer must use an approved, established agency that is recognized as regularly engaged in conducting tests or furnishing inspection services. An approved agency will issue certificate of compliance stating that materials and products meet specified standards or that work was done in compliance and with approved construction documents.

For further reference go to the two sites listed below:

http://www.fema.gov/plan/prevent/earthquake/professionals.shtm_FieldManual.pdf

<http://www.iccsafe.org/cc/>

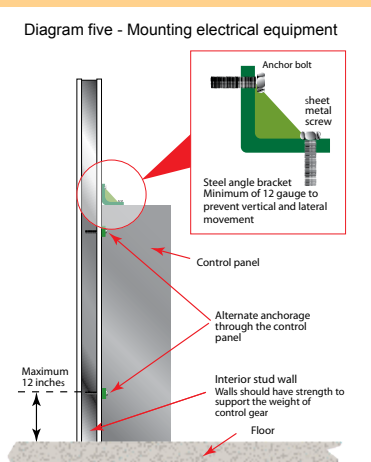
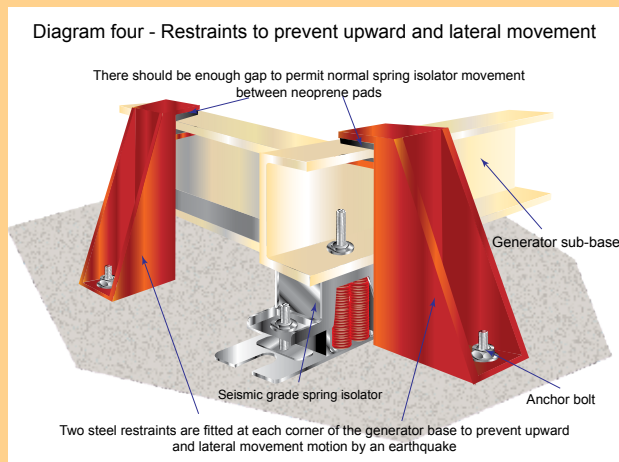
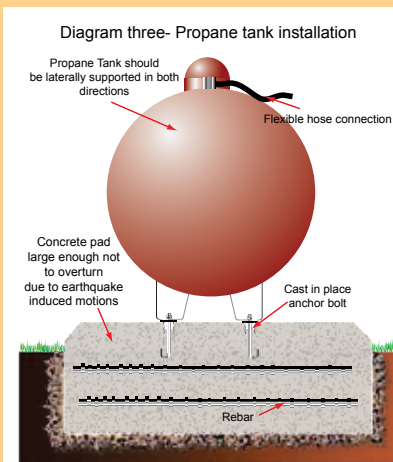

Oklahoma City Area
7300 Melrose Lane
Oklahoma City
OK 73127
405.949.2332
405.842.4864 fax

Austin Area
4918 Burleson Road
Austin
TX 78744
512.477.6937
512.477.6938 fax

Tulsa Mailing Address
P.O. Box 581807
Tulsa
OK 74158-1807
918.836.0066
918.836.0094 fax

Dallas/Ft. Worth Area
101 Industrial Boulevard
Mansfield
TX 76063
817.640.5544
817.477.2938 fax

Longview Area
1913 East US Hwy 80
White Oak
TX 75693
903.291.8305
903.291.8327 fax

San Antonio Area
4702 B Dodge Street
San Antonio
TX 78217
201.333.0377
201.653.7121 fax

Little Rock Area
29 Collins Industrial Place
Building 1C
North Little Rock, AR 72113
501.907.5884
501.907.4702 fax



Tulsa Corporate Headquarters Physical Address • 9310 East 46th Street North • Tulsa • OK • 74117 • 1.800.324.0066 • www.cliffordpower.com